

FOX LEA FARM
VENICE, FLORIDA

2021 Winter Circuit Pattern Book

S/C 1

Western Riding-

Green/Novice Level 1- Pattern 4

All others- Pattern 4

Reining-

Pattern 3

Ranch Riding-

Pattern 10

REINING PATTERN 3

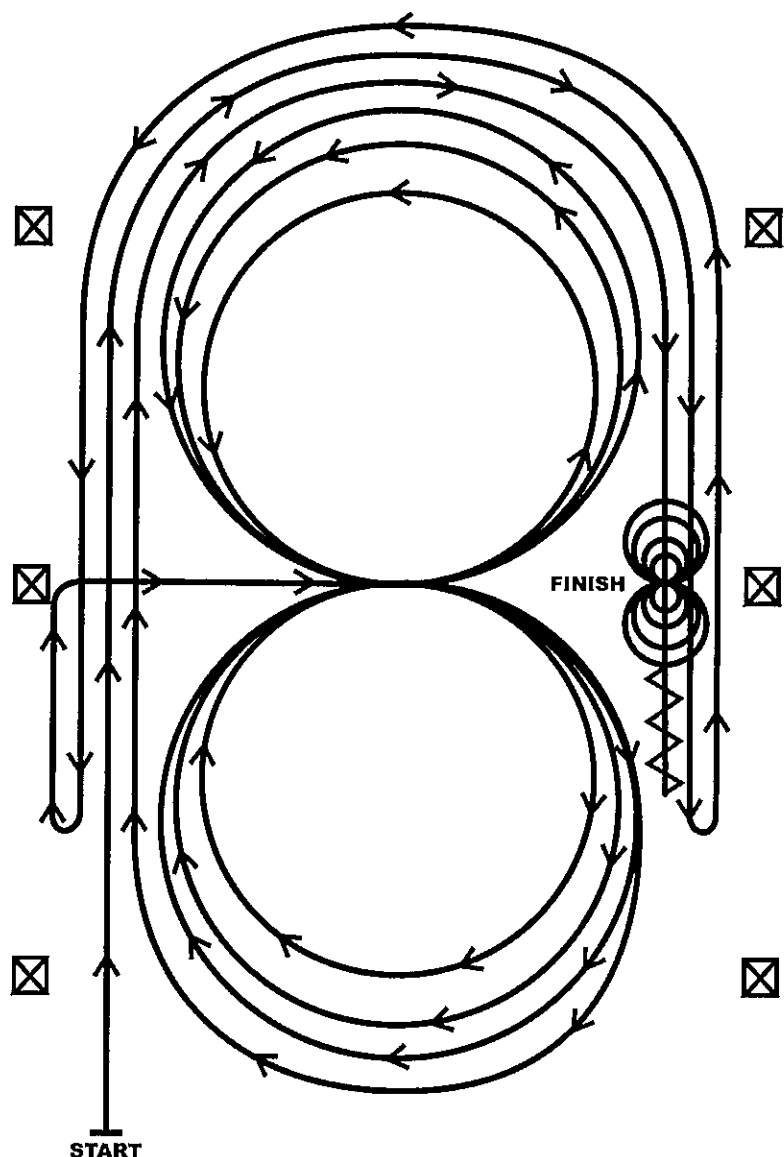

1. Beginning, lope straight up the left side of the arena, circle the top end of the arena, and staying at least twenty feet (six meters) from the walls or fence, run straight down the opposite or right side of the arena past the center marker and do a left rollback—no hesitation.
2. Continue straight up the right side of the arena circle back around the top of the arena, and staying at least twenty feet (six meters) from the walls or fence, run straight down the left side of the arena past the center marker and do a right rollback—no hesitation.
3. Continue up the left side of the arena to the center marker. At the center marker, the horse should be on the right lead. Guide the horse to the center of the arena on the right lead and complete three circles to the right: the first two circles large and fast; the third circle small and slow. Change leads at the center of the arena.
4. Complete three circles to the left: the first two circles large and fast; the third circle small and slow. Change leads in the center of the arena.
5. Begin a large circle to the right but do not close this circle. Continue up the left side of the arena, circle the top of the arena, and staying at least twenty feet (six meters) from the walls or fence, run straight down the opposite or right side of the arena past the center marker and do a sliding stop. Back up at least ten feet (three meters). Hesitate.
6. Complete four spins to the right. Hesitate.
7. Complete four spins to the left. Hesitate to demonstrate completion of the pattern.

RANCH RIDING - PATTERN 10

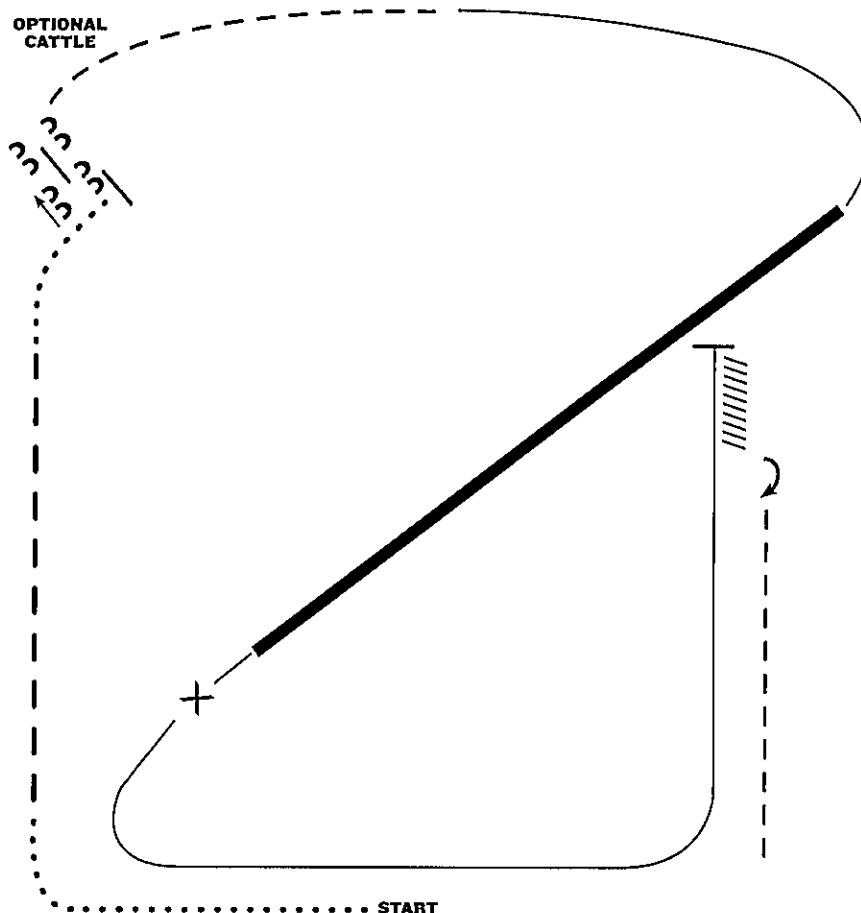

1. Walk
2. Extended trot
3. Walk
4. Stop, side pass log left
5. Trot
6. Lope right lead
7. Extended Lope (right lead)
8. Collect lope and change leads (simple or flying)
9. Lope left lead
10. Stop and back
11. 180 turn to right
12. Trot

Note: The drawn description of this pattern is only intended for the general depiction of the pattern. Exhibitors should utilize the arena space to best exhibit their horses.

Winter Circuit

Showmanship (L1 Amateur & L1 Youth)

Show Date: January 8, 2021 S/C 1

W W W . H O R S E S H O W P A T T E R N S . C O M

W W W . H O R S E S H O W P A T T E R N S . C O M

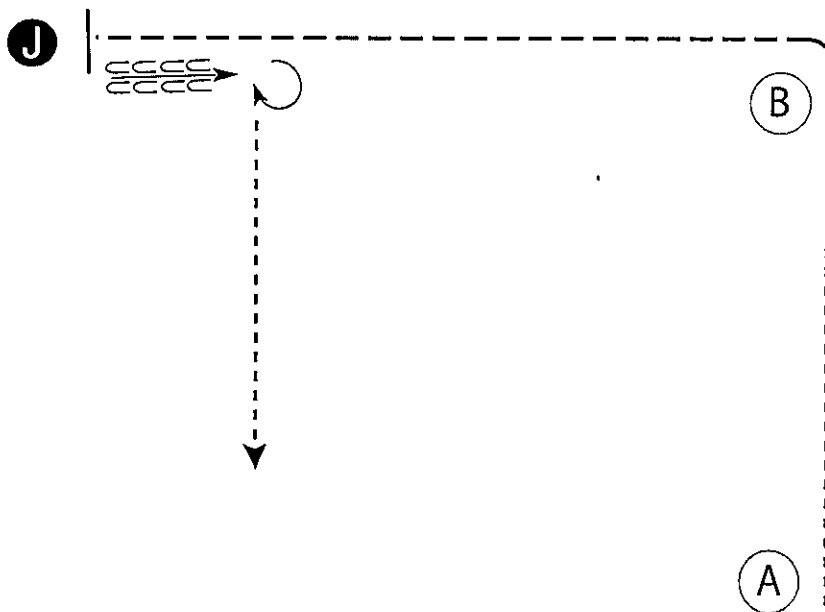

Be ready at A.

1. Walk to B.
2. Trot around B and to judge.
3. Stop and set up for inspection.
4. When dismissed, back one horse length.
5. Turn 270 degrees and walk straight off.

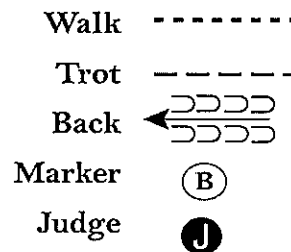

[S/1-23]

Pattern Provided by:

The Judges

Winter Circuit

Showmanship (Youth, Amateur & Select)

Show Date: January 8, 2021 S/C 1

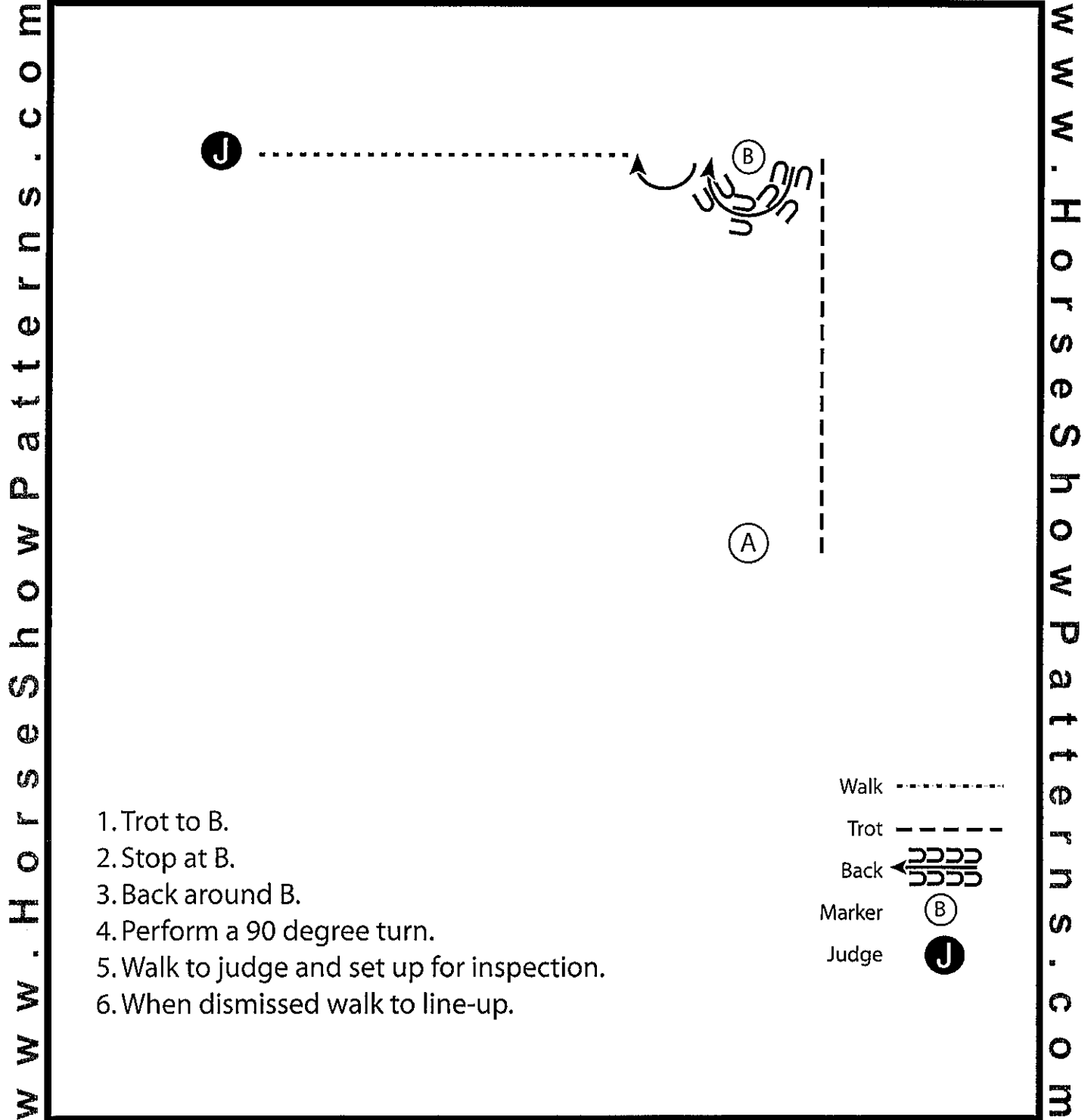

[S/2-5]

Pattern Provided by:

The Judges

Winter Circuit

Showmanship (Walk Trot, Small Fry)

Show Date: January 8, 2021 S/C 1

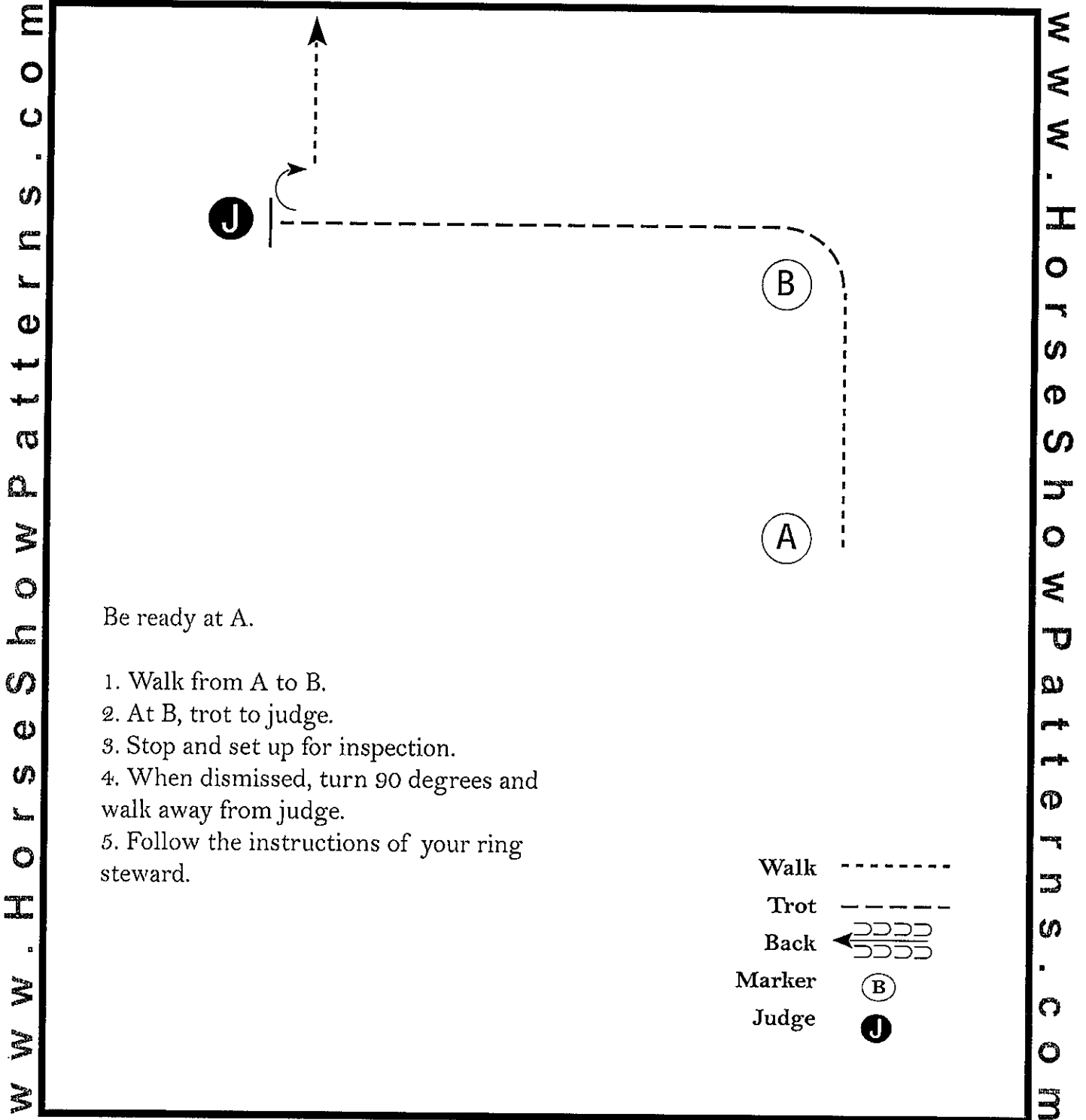

[SWT-11]

Pattern Provided by:

The Judges

Winter Circuit

Equitation (L1 Amateur & L1 Youth)

Show Date: January 8, 2021 S/C 1

w w w . H o r s e S h o w P a t t e r n s . c o m

w w w . H o r s e S h o w P a t t e r n s . c o m

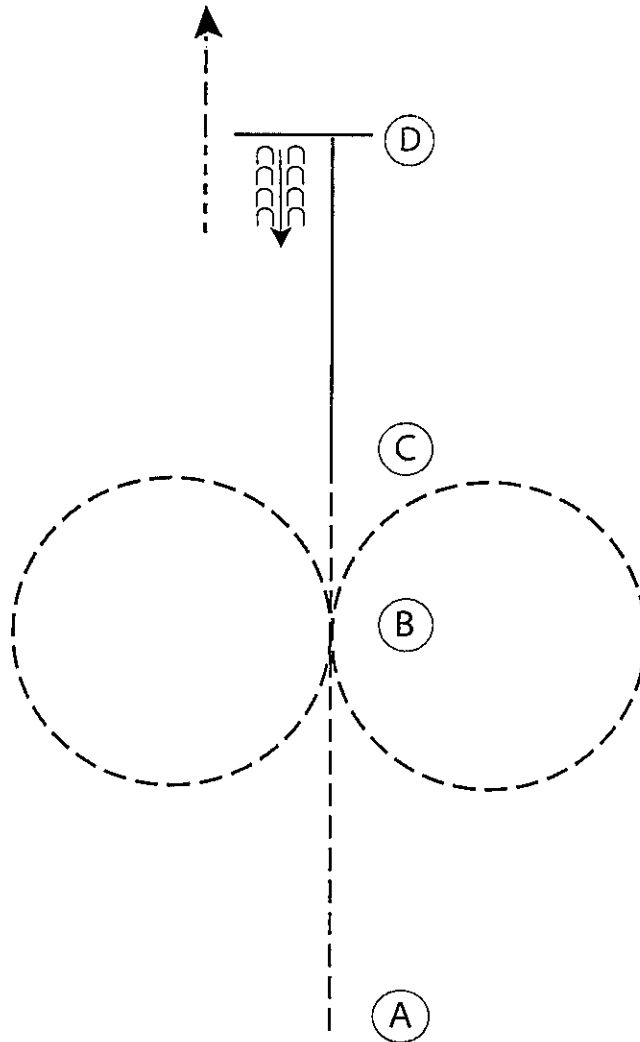

1. Sitting trot from A to B
2. Perform a figure eight at the posting trot starting to the right
3. Continue posting trot to C
4. Canter right lead to D
5. At D stop and back five steps
6. Walk five steps and trot to the line

Walk	-----
Trot	- - - - -
Extended Trot	— — — — —
Canter	— — — — —
Leg Yield	
Lead Change	— / —
Back	← C C C C C
Marker	⊙
Sidepass	← - - - - - →
Hand Gallop	— — — — —

[HSE/1-5]

Pattern Provided by:

The Judges

Winter Circuit

Equitation (Youth, Amateur & Select)

Show Date: January 8, 2021 S/C 1

W W W . H o r s e S h o w P a t t e r n s . c o m

W W W . H o r s e S h o w P a t t e r n s . c o m

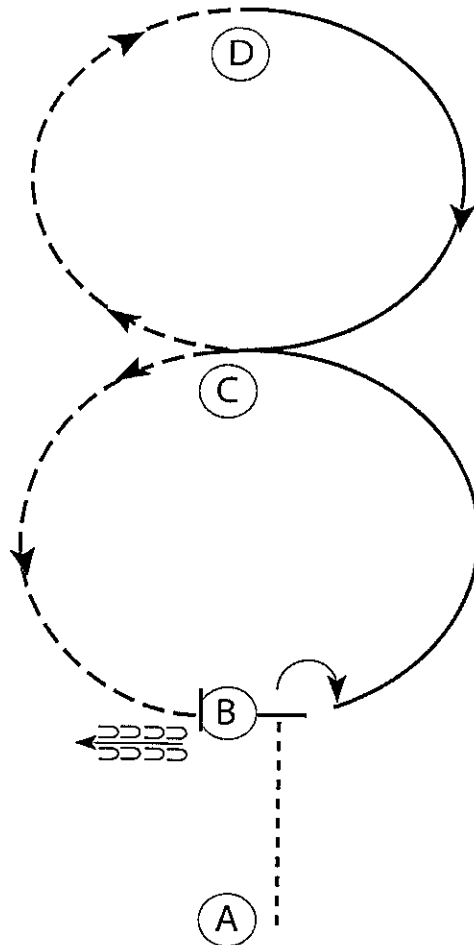

Be ready at A.

1. Walk to B.
2. Stop at B and perform a 90 degree turn to the right on the forehand.
3. Canter on the left lead to C.
4. Posting trot from C to D.
5. Canter on the right lead from D to C.
6. Posting trot from C to B.
7. Stop at B and back one horse length.

Follow the instructions of your ring steward.

Walk	-----
Trot	- - - - -
Extended Trot	— — — — —
Canter	—————
Leg Yield	
Lead Change	↘ ↙
Back	← ← ← ← ←
Marker	⊙ B
Sidepass	← - - - - ←
Hand Gallop	— — — — —

[HSE/2-13]

Pattern Provided by:
The Judges

Winter Circuit

Equitation (Walk Trot, Small Fry)

Show Date: January 8, 2021 S/C 1

www.HorseShowPatterns.com

www.HorseShowPatterns.com

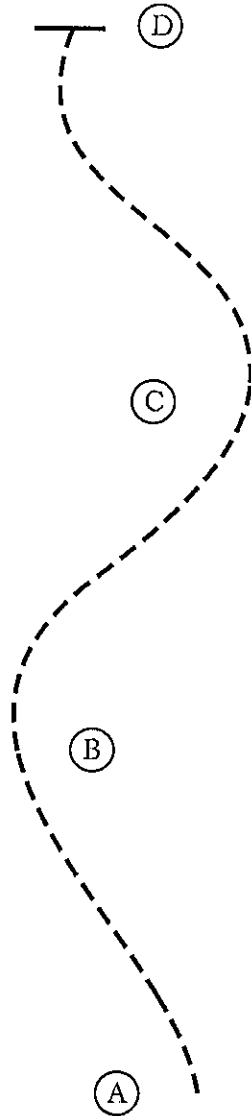

1. Sitting trot A to B
2. At B posting trot to C on the left diagonal
3. At C change diagonals and posting trot to D
4. Stop at D

Walk
Trot	-----
Extended Trot	-----
Canter	—————
Leg Yield	
Lead Change	↘
Back	←←←←
Marker	⊙ B
Sidepass	←←←←

[HSE/WT-8]

Pattern Provided by:

The Judges

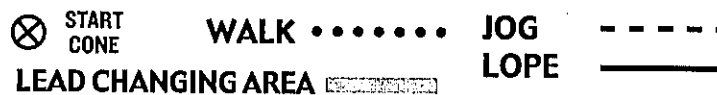
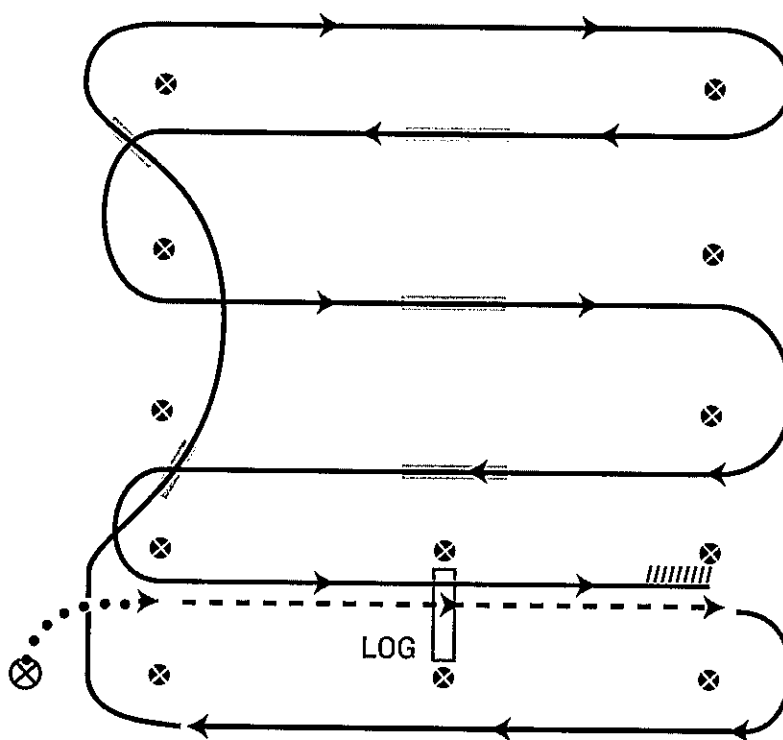
LEVEL I WESTERN RIDING PATTERN 4

1. Walk at least 15 feet from start cone to the first marker, transition to jog, jog over log.
2. Transition to right lead & lope around end
3. First line change
4. Second line change, lope around end of arena
5. First crossing change
6. Second crossing change
7. Third crossing change
8. Lope over log
9. Lope, stop & back

Sk 1

WESTERN RIDING PATTERN 4

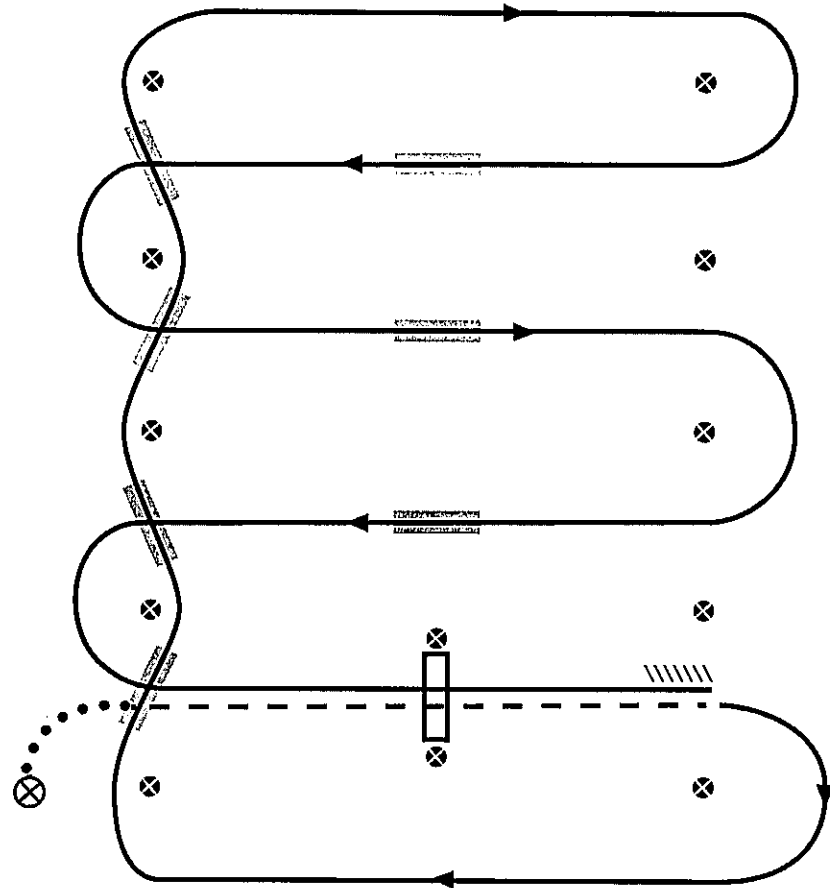

⊗ START CONE WALK JOG
 LEAD CHANGING AREA [Hatched] LOPE ———

1. Walk at least 15 feet from start cone to the first marker, transition to jog, jog over log.
2. Transition to the lope, on the right lead
3. First line change
4. Second line change
5. Third line change
6. Fourth line change
7. First crossing change
8. Second crossing change
9. Third crossing change
10. Lope over log
11. Lope, stop & back

Winter Circuit

Horsemanship (L1 Amateur & L1 Youth)

Show Date: January 9, 2021 S/C 1

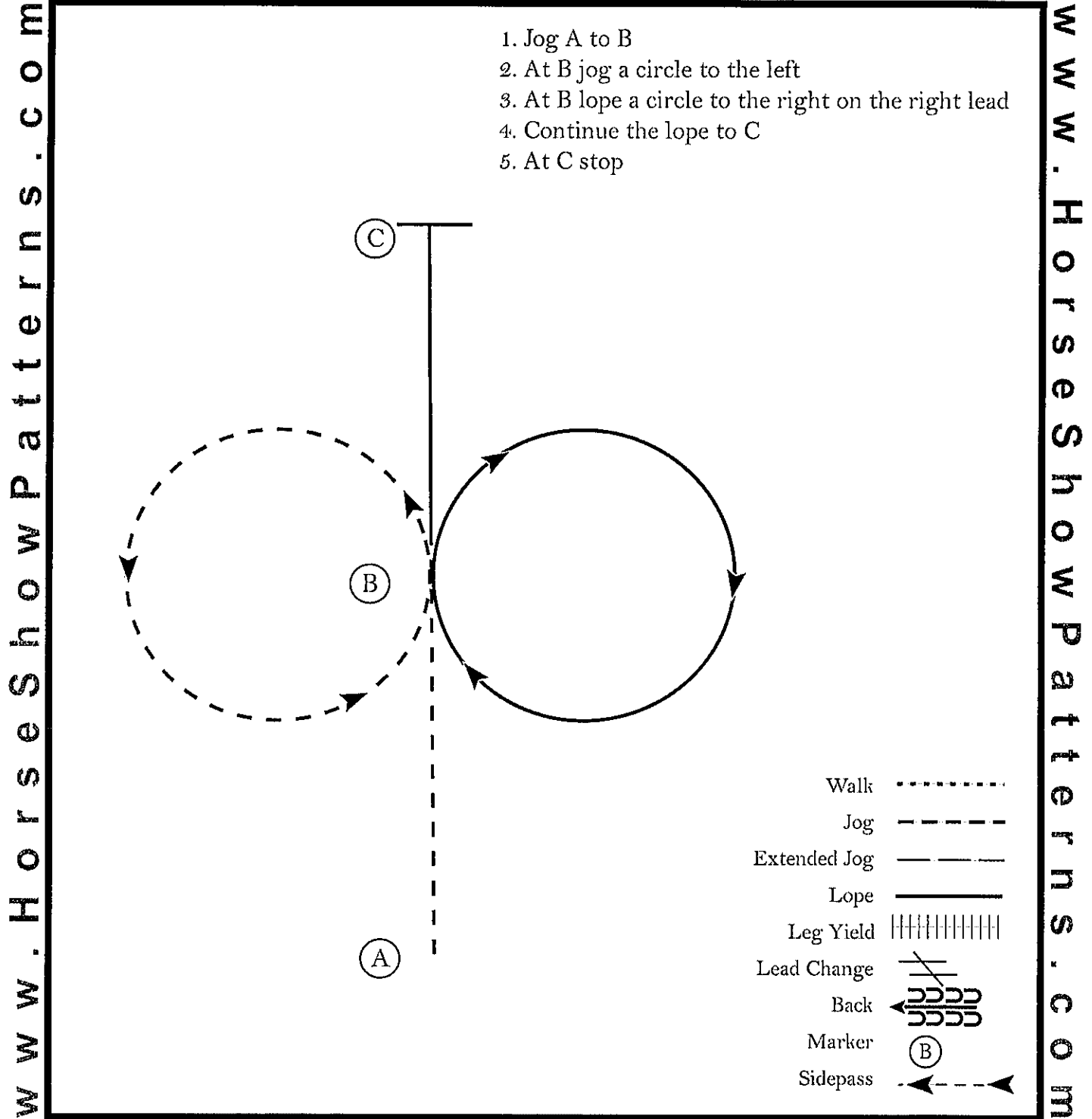

[WH/1-9]

Pattern Provided by:

The Judges

Winter Circuit

Horsemanship (Walk Trot, Small Fry)

Show Date: January 9, 2021 S/C 1

w w w . H o r s e S h o w P a t t e r n s . c o m

w w w . H o r s e S h o w P a t t e r n s . c o m

1. Jog A to B
2. At B perform a figure eight, beginning to the right
3. Continue the jog from B to C
4. At C stop and back 4 steps

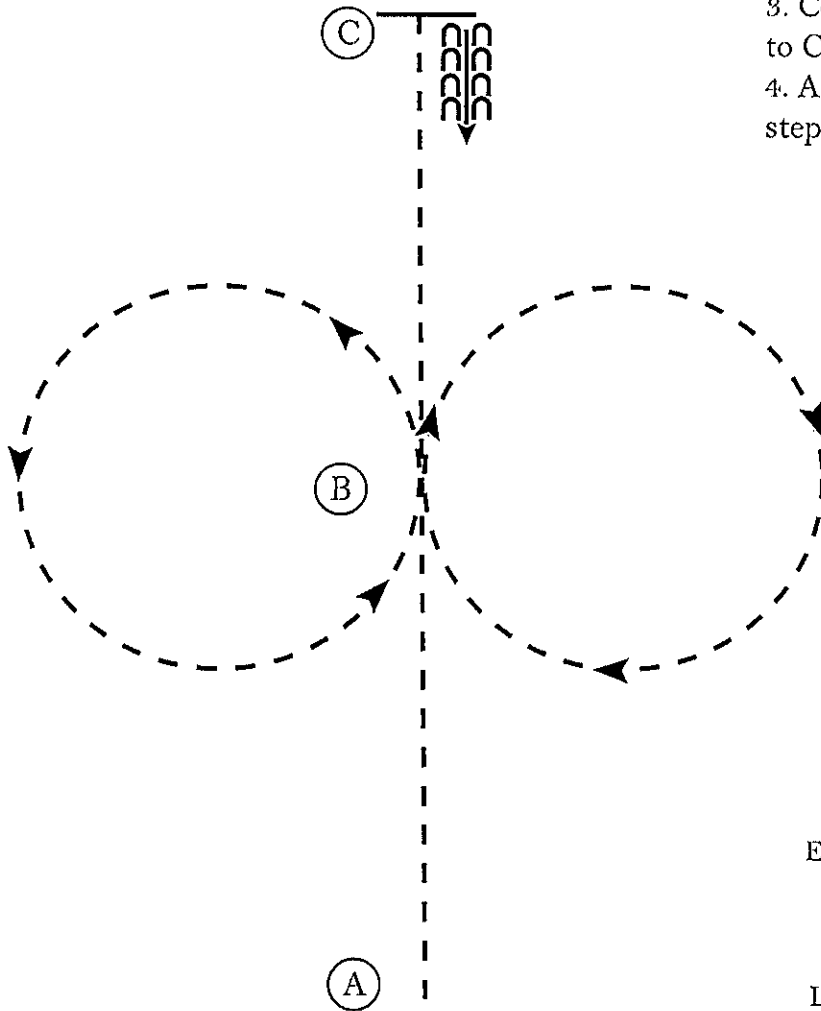

- Walk (dotted line)
- Jog - - - - - (dashed line)
- Extended Jog - - - - - (long-dashed line)
- Lope - - - - - (solid line)
- Leg Yield ||||| (vertical bars)
- Lead Change / (diagonal line)
- Back ←←← (curved arrows pointing left)
- Marker (B) (circle with B)
- Sidepass → - - - - - (dashed line with arrow)

[WH/WT-5]

Pattern Provided by:

The Judges

Fox Lea Winter Circuit

Western Horsemanship (Youth, Amateur, Select)

Show Date: 01-09-2021 S/C 1

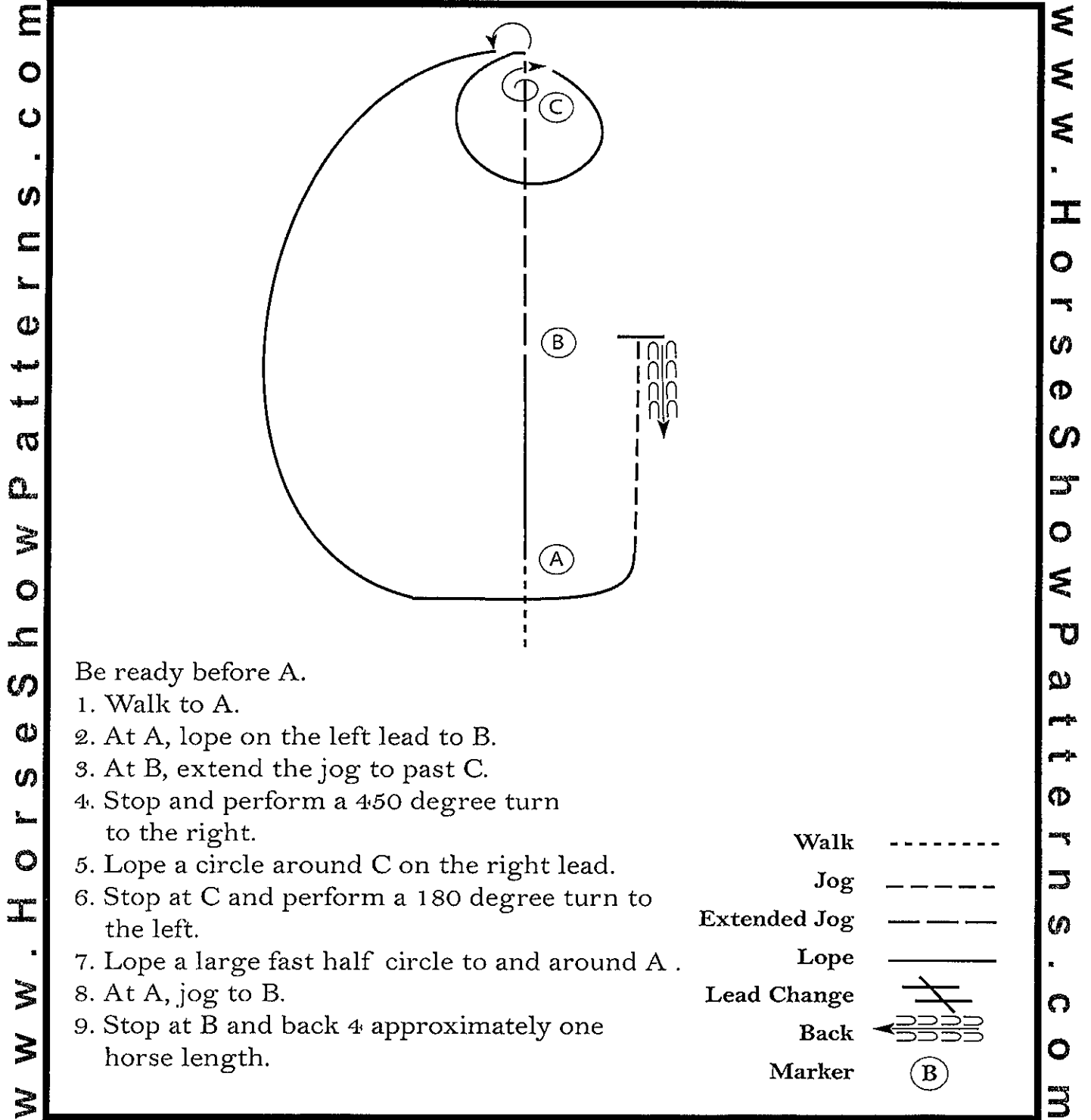

Be ready before A.

1. Walk to A.
2. At A, lope on the left lead to B.
3. At B, extend the jog to past C.
4. Stop and perform a 450 degree turn to the right.
5. Lope a circle around C on the right lead.
6. Stop at C and perform a 180 degree turn to the left.
7. Lope a large fast half circle to and around A .
8. At A, jog to B.
9. Stop at B and back 4 approximately one horse length.

Walk	-----
Jog	- - - - -
Extended Jog	- - - - -
Lope	—————
Lead Change	⋈
Back	←←←←←
Marker	Ⓚ

[WH/3-8]

Pattern Provided by:

2021 FOX LEA FARMS
FUN IN THE SUN
SUN JAN 10TH

AMATEUR AND SELECT TRAIL
YOUTH AND SENIOR TRAIL

5/1

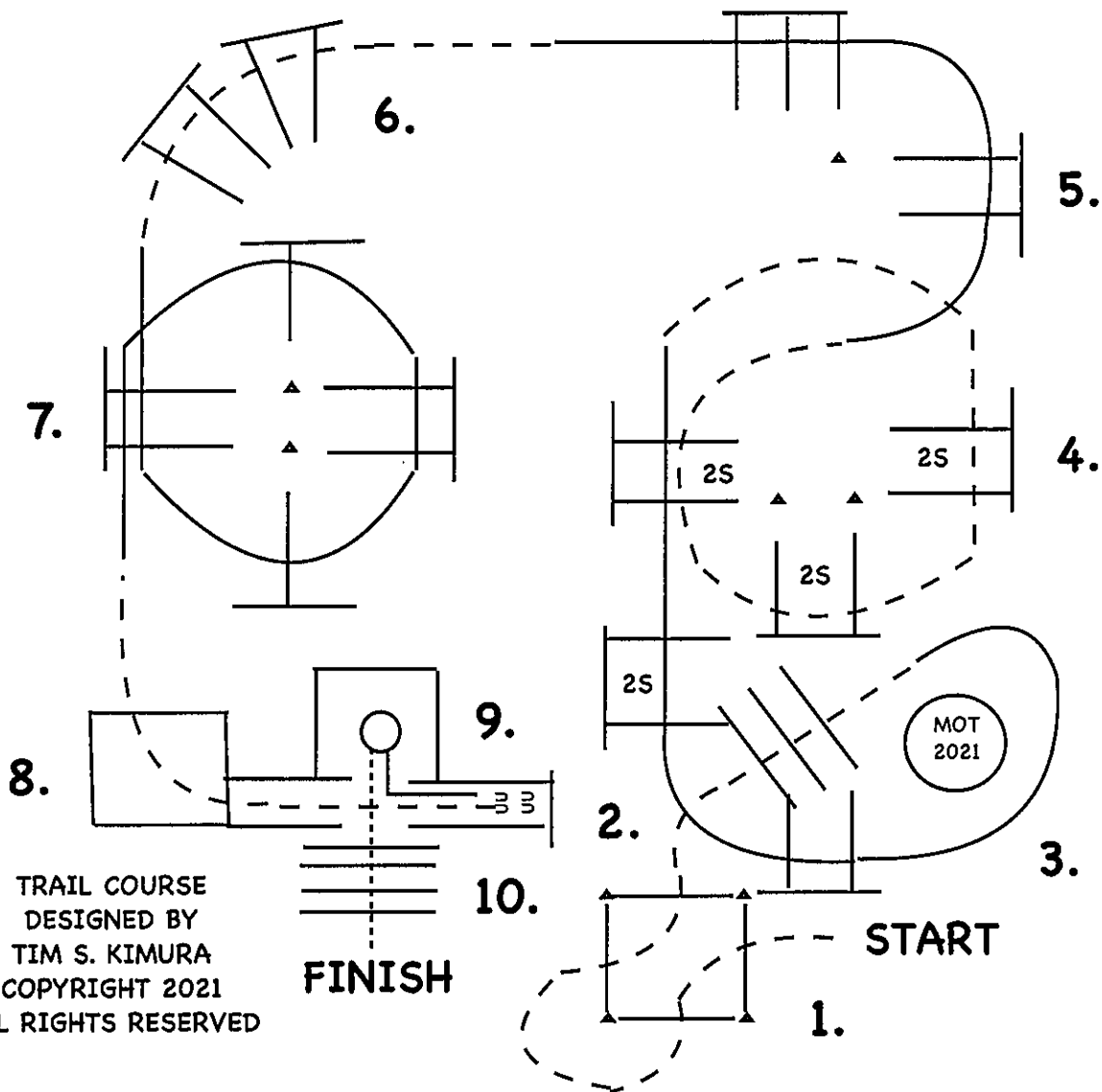

TRAIL COURSE
DESIGNED BY
TIM S. KIMURA
COPYRIGHT 2021
ALL RIGHTS RESERVED

1. JOG OVER POLES, JOG AROUND CONES.
2. JOG OVER POLES.
3. LOPE OVER POLES (RIGHT LEAD).
4. BREAK TO THE JOG, JOG OVER POLES.
5. LOPE OVER POLES (RIGHT LEAD).
6. BREAK TO THE JOG, JOG OVER POLES.
7. LOPE OVER POLES (LEFT LEAD).
8. BREAK TO THE JOG, JOG OVER POLES, JOG INTO CHUTE BACK AROUND CORNER INTO BOX.
9. EXECUTE A 360 TURN EITHER WAY.
10. WALK OUT BOX, WALK OVER POLES.

2021 FOX LEA FARMS
FUN IN THE SUN
SUN JAN 10TH

4 & OV NOVICE HORSE
L1 JR, L1 SR, L1 AM, L1 YOUTH

skt

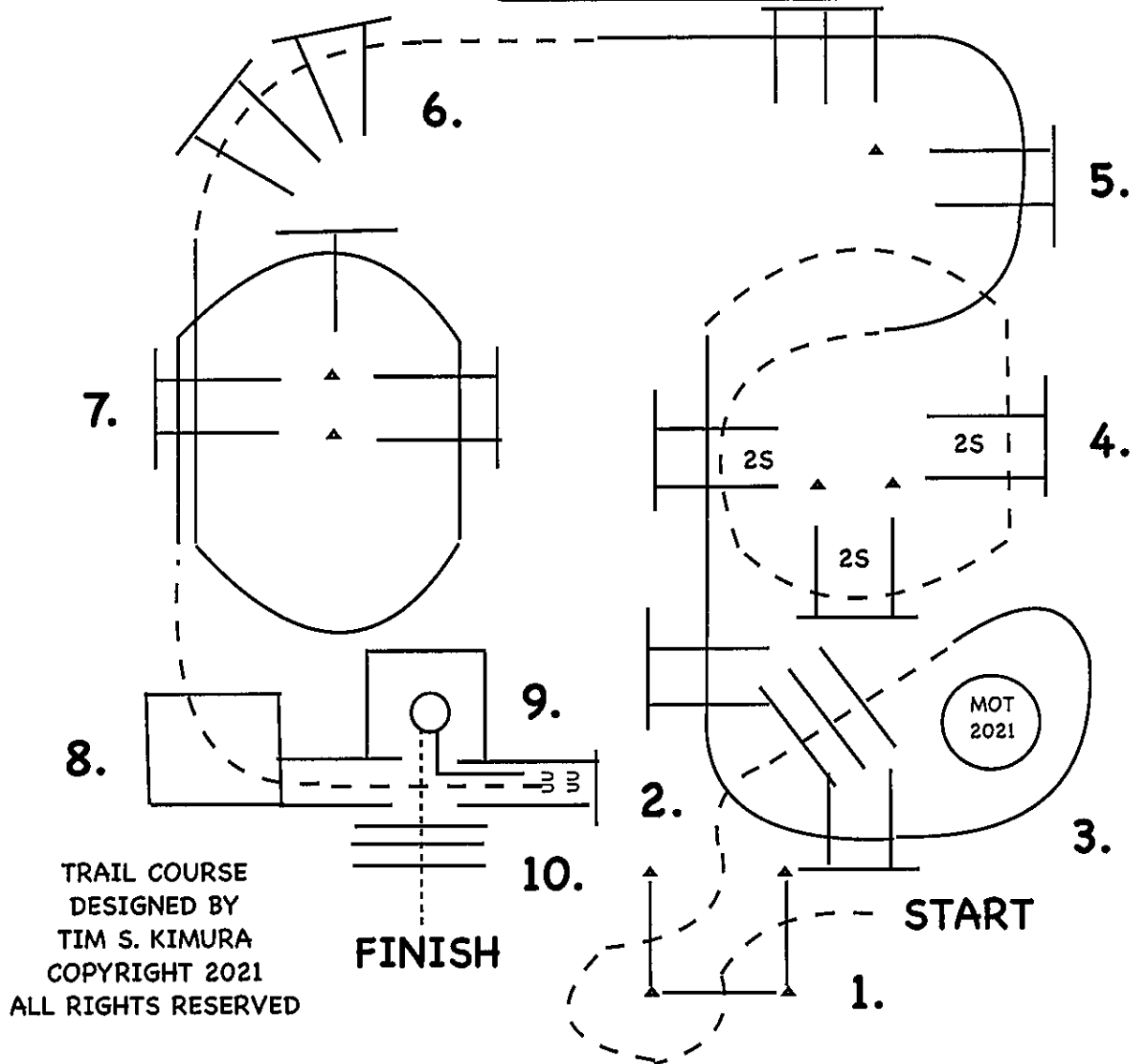

1. JOG OVER POLES, JOG AROUND CONES.
2. JOG OVER POLES.
3. LOPE OVER POLES (RIGHT LEAD).
4. BREAK TO THE JOG, JOG OVER POLES.
5. LOPE OVER POLES (RIGHT LEAD).
6. BREAK TO THE JOG, JOG OVER POLES.
7. LOPE OVER POLES (LEFT LEAD).
8. BREAK TO THE JOG, JOG OVER POLES, JOG INTO CHUTE BACK AROUND CORNER INTO BOX.
9. EXECUTE A 360 TURN EITHER WAY.
10. WALK OUT BOX, WALK OVER POLES.

2021 FOX LEA FARMS
FUN IN THE SUN
SUN JAN 10TH

L1 AMATEUR WT TRAIL
L1 YOUTH WT TRAIL

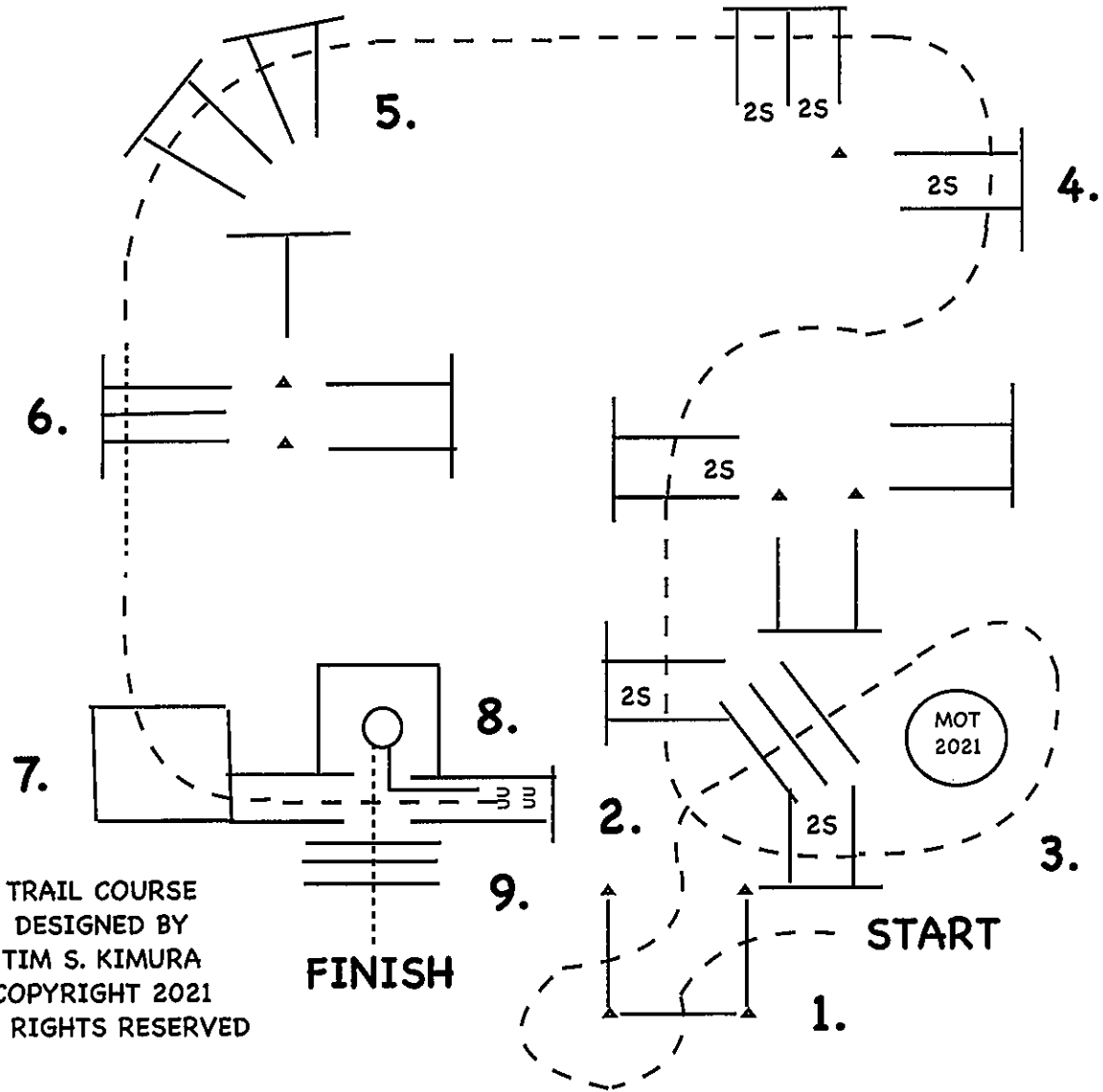

TRAIL COURSE
DESIGNED BY
TIM S. KIMURA
COPYRIGHT 2021
ALL RIGHTS RESERVED

1. JOG OVER POLES, JOG AROUND CONES.
2. JOG OVER POLES.
3. JOG OVER POLES.
4. JOG OVER POLES.
5. JOG OVER POLES.
6. STOP OR BREAK TO THE WALK, WALK OVER POLES
7. JOG OVER POLES, JOG INTO CHUTE
BACK AROUND CORNER INTO BOX.
8. EXECUTE A 360 TURN EITHER WAY.
9. WALK OUT BOX, WALK OVER POLES.

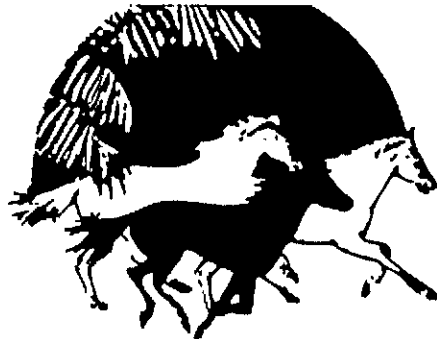

FOX LEA FARM
VENICE, FLORIDA

2021 Winter Circuit Pattern Book

S/C 2

Western Riding-

Green/Novice Level 1- Pattern

1 All others- Pattern 1

Reining-

Pattern 7

Ranch Riding-

Pattern 1

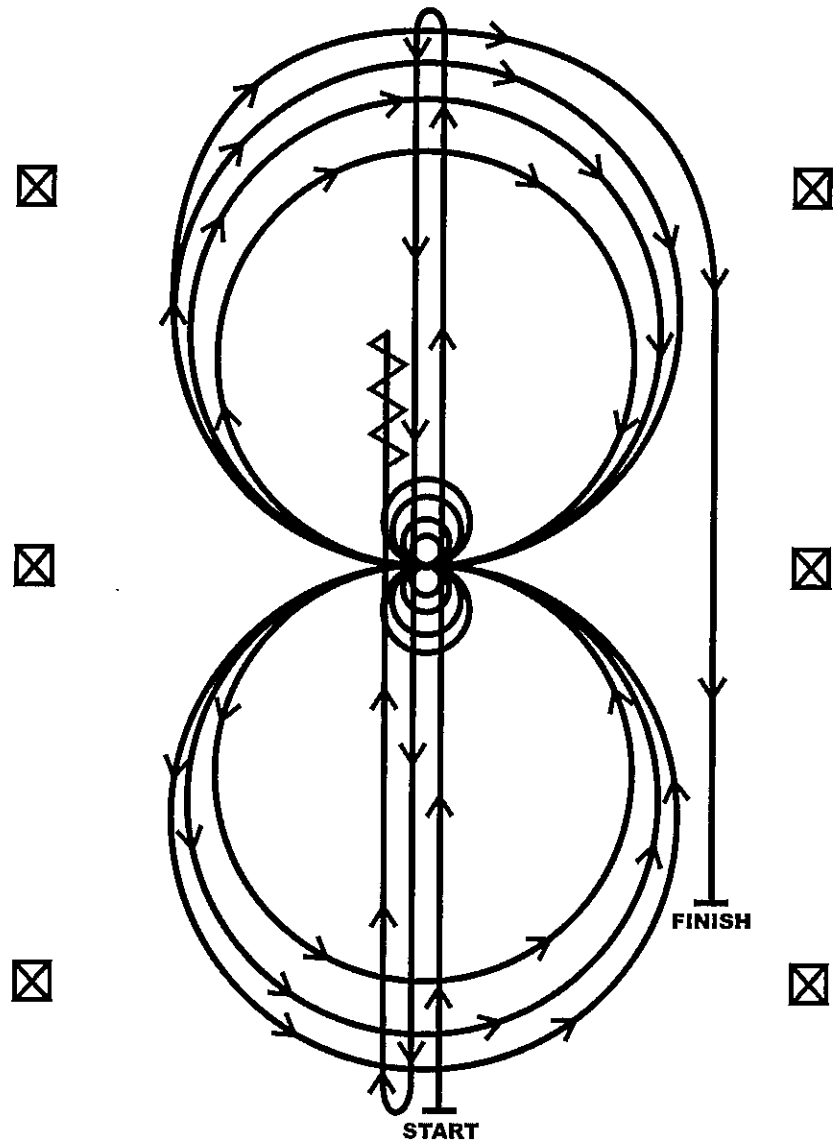
REINING PATTERN 7

1. Run at speed to the far end of the arena past the end marker and do a left rollback—no hesitation.
2. Run to the opposite end of the arena past the end marker and do a right rollback—no hesitation.
3. Run past the center marker and do a sliding stop. Back up to the center of the arena or at least ten feet (three meters). Hesitate.
4. Complete four spins to the right. Hesitate.
5. Complete four and one-quarter spins to the left so that horse is facing left wall or fence. Hesitate.
6. Beginning on the right lead, complete three circles to the right: the first two circles large fast; the third circle small and slow. Change leads at the center of the arena.
7. Complete three circles to the left: the first two circles large fast; the third circle small and slow. Change leads at the center of the arena.
8. Begin a large circle to the right but do not close this circle. Run straight down the right side of the arena past the center marker and do a sliding stop at least twenty feet (six meters) from the wall or fence. Hesitate to demonstrate completion of the pattern.

RANCH RIDING - PATTERN I

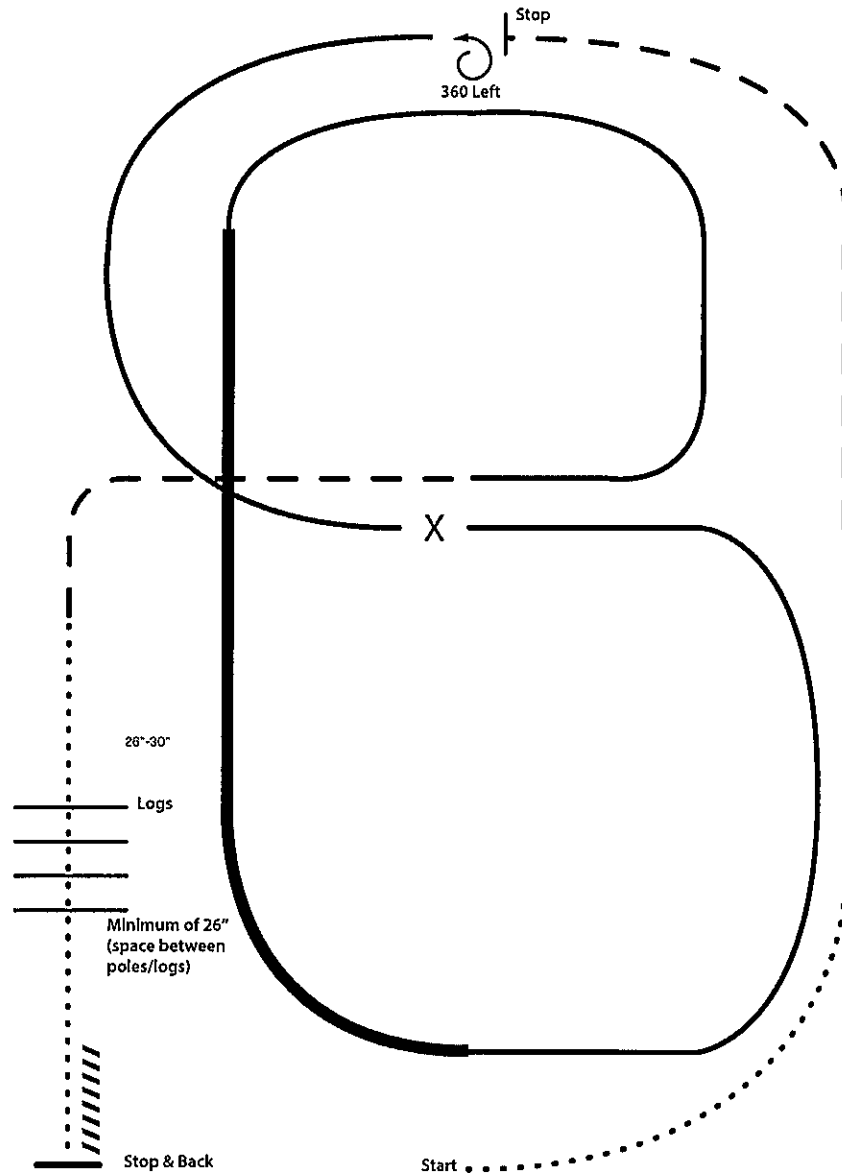

- X Lead Change
- Walk
- - - Trot
- — — Ext Trot
- ==== Lope
- ===== Ext Lope
- /////// Back

1. Walk
2. Trot
3. Extend the trot, at the top of the arena ,stop
4. 360 degree turn to the left
5. Left lead 1/2 circle, lope to the center
6. Change leads (simple or flying)
7. Right lead 1/2 circle
8. Extended lope up the long side of the arena (right lead)
9. Collect back to a lope around the top of the arena and back to center
10. Break down to an extended trot
11. Walk over logs
12. Stop and back

Fox Lea Farms Winter Circuit

Hunt Seat Equitation (L1 Youth, L1 Amateur)

Show Date: January 13, 2021 S/C 2

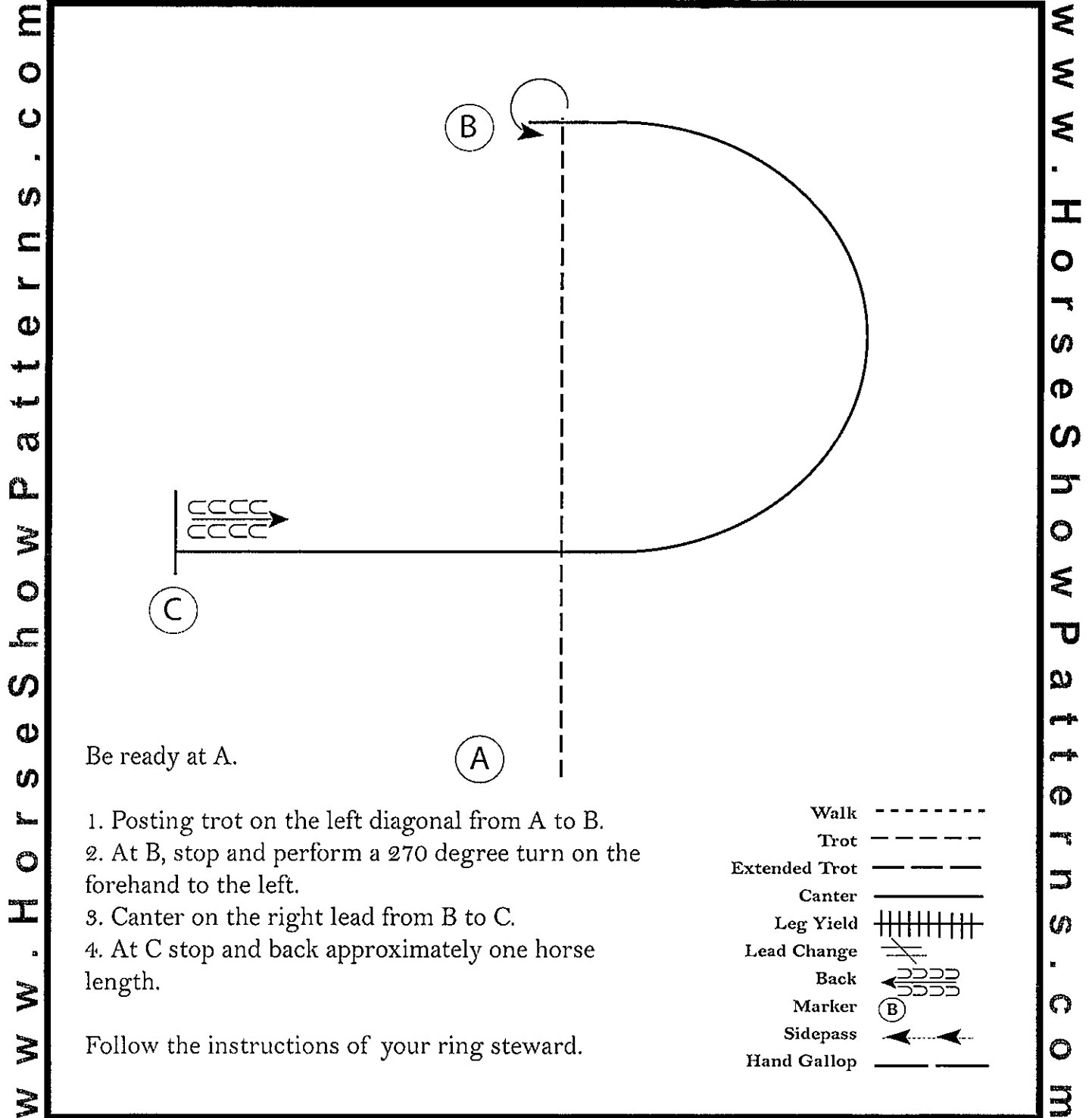

Be ready at A.

1. Posting trot on the left diagonal from A to B.
2. At B, stop and perform a 270 degree turn on the forehand to the left.
3. Canter on the right lead from B to C.
4. At C stop and back approximately one horse length.

Follow the instructions of your ring steward.

Walk	-----
Trot	- - - - -
Extended Trot	-----
Canter	-----
Leg Yield	
Lead Change	-----
Back	←←←
Marker	ⓑ
Sidepass	←-----→
Hand Gallop	-----

[HSE/1-30]

Pattern Provided by:

Judges Pool

Fox Lea Farms Winter Circuit

Hunt Seat Equitation (Youth, Amateur, Select)

Show Date: January 13, 2021 S/C 2

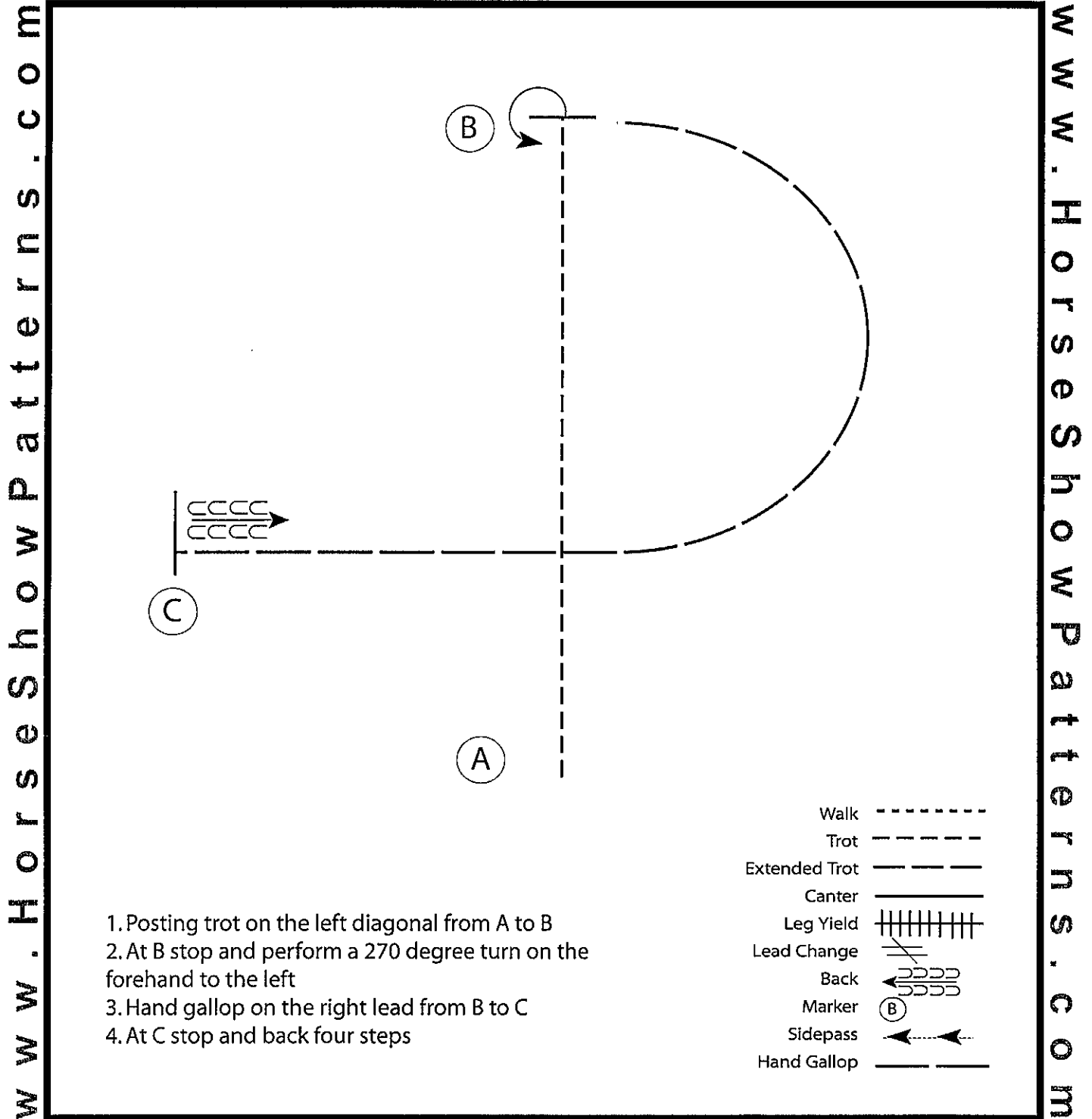

1. Posting trot on the left diagonal from A to B
2. At B stop and perform a 270 degree turn on the forehand to the left
3. Hand gallop on the right lead from B to C
4. At C stop and back four steps

Walk	-----
Trot	- - - - -
Extended Trot	-----
Canter	=====
Leg Yield	
Lead Change	↘
Back	←←←←
Marker	Ⓚ
Sidepass	←-----→
Hand Gallop	-----

[HSE/2-30]

Pattern Provided by:
Judges Pool

Fox Lea Farms Winter Circuit

Hunt Seat Equitation (Walk Trot, Small Fry)

Show Date: January 13, 2021 S/C 2

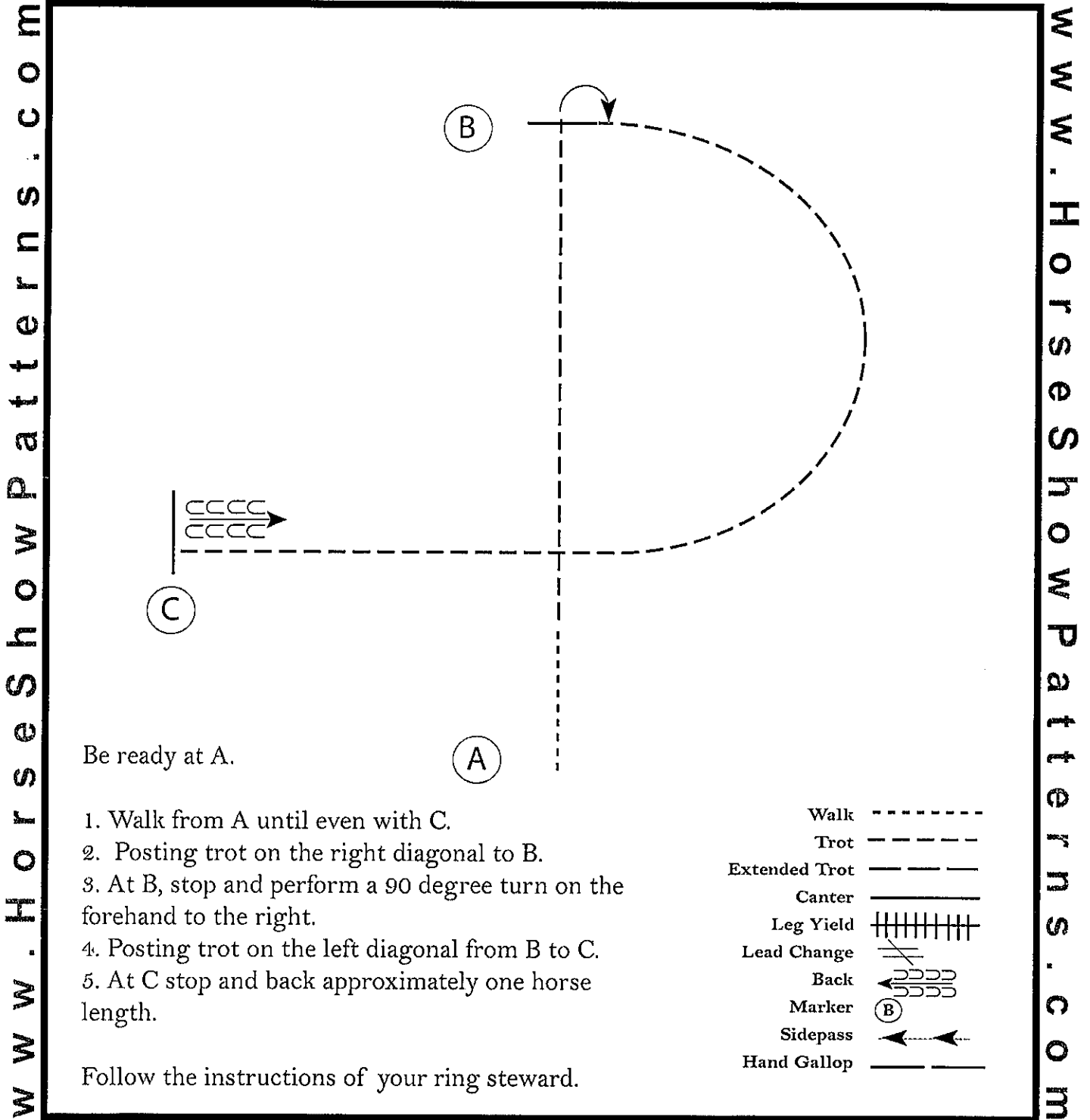

[HSE/WT-30]

Pattern Provided by:

Judges Pool

Fox Lea Winter Circuit

Western Horsemanship (Level 1 Youth, Level 1 Amateur)

Show Date: 1-11-2020 S/C 2

w w w . H o r s e S h o w P a t t e r n s . c o m

w w w . H o r s e S h o w P a t t e r n s . c o m

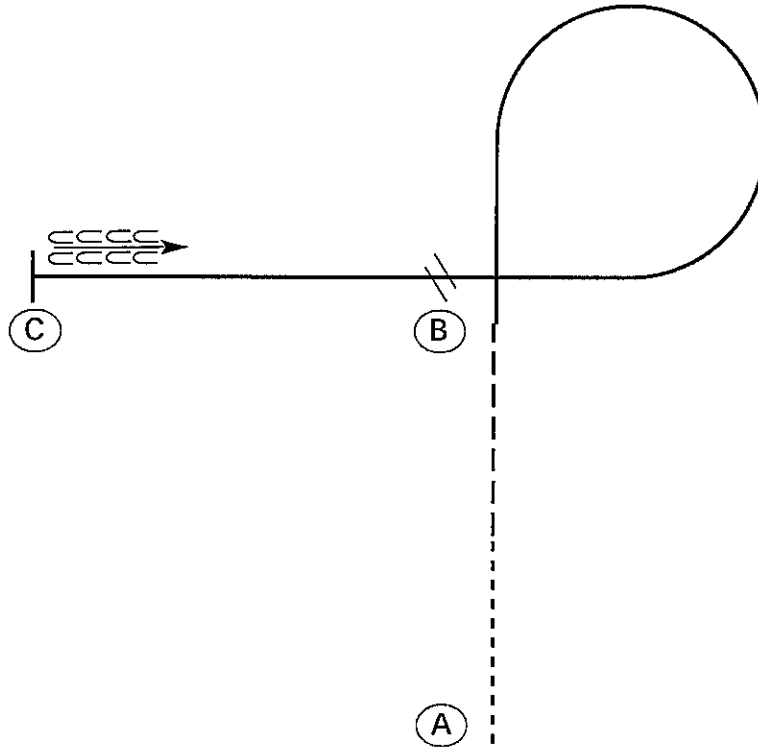

Be ready at A.

1. Walk from A 1/2 way to B.
2. Jog the rest of the way to B.
3. Lope a circle to the right.
4. Change leads at B.
5. Lope on the left lead to C.
6. Stop at C and back one horse length.

Retire to the rail or line up at a jog.

Walk
Jog	-----
Extended Jog	-----
Lope	—————
Leg Yield	
Lead Change	⋈
Back	←←← ←←←
Marker	(B)
Sidepass	←-----→

[WH/2-25]

Pattern Provided by:

The Judges

Fox Lea Winter Circuit

Western Horsemanship (Youth, Amateur, Select)

Show Date: 1-11-2020 S/C 2

www.HorseShowPatterns.com

www.HorseShowPatterns.com

1. Jog A to B
2. Stop at B and perform a 180 degree turn to the left
3. Lope a small slow circle to the left on the right lead
4. At B perform a lead change and lope a larger faster circle to the left
5. Stop at B and perform a 360 degree turn to the right
6. Extend the jog in a circle and then continue on the C
7. Stop at C

Walk
Jog	-----
Extended Jog	-----
Lope	—————
Leg Yield	
Lead Change	↘
Back	←←←←
Marker	⊙ B
Sidepass	→←

[WH/3-12]

Pattern Provided by:

The Judges

Fox Lea Farms Winter Circuit

Horsemanship (Walk-Jog, Small Fry)

Show Date: January 11, 2021 S/C 2

www.HorseShowPatterns.com

www.HorseShowPatterns.com

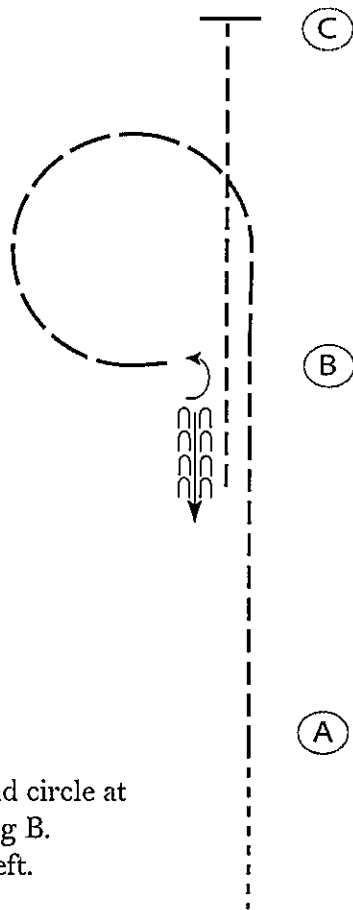

Begin before A at a walk.

1. Jog from A to B.
2. At B, extend the jog and circle at B as shown. Stop facing B.
3. Turn 1/4 turn to the left.
4. Back one horse length.
5. Jog to C. Stop at C.

Follow the instructions of your ring steward.

Walk
Jog	-----
Extended Jog	—————
Lope	—————
Leg Yield	
Lead Change	—/—
Back	←←←←←
Marker	⊙
Sidepass	←-----→

[WH/WT-17]

Pattern Provided by:

Judges Pool

LEVEL I WESTERN RIDING PATTERN I

S/CZ

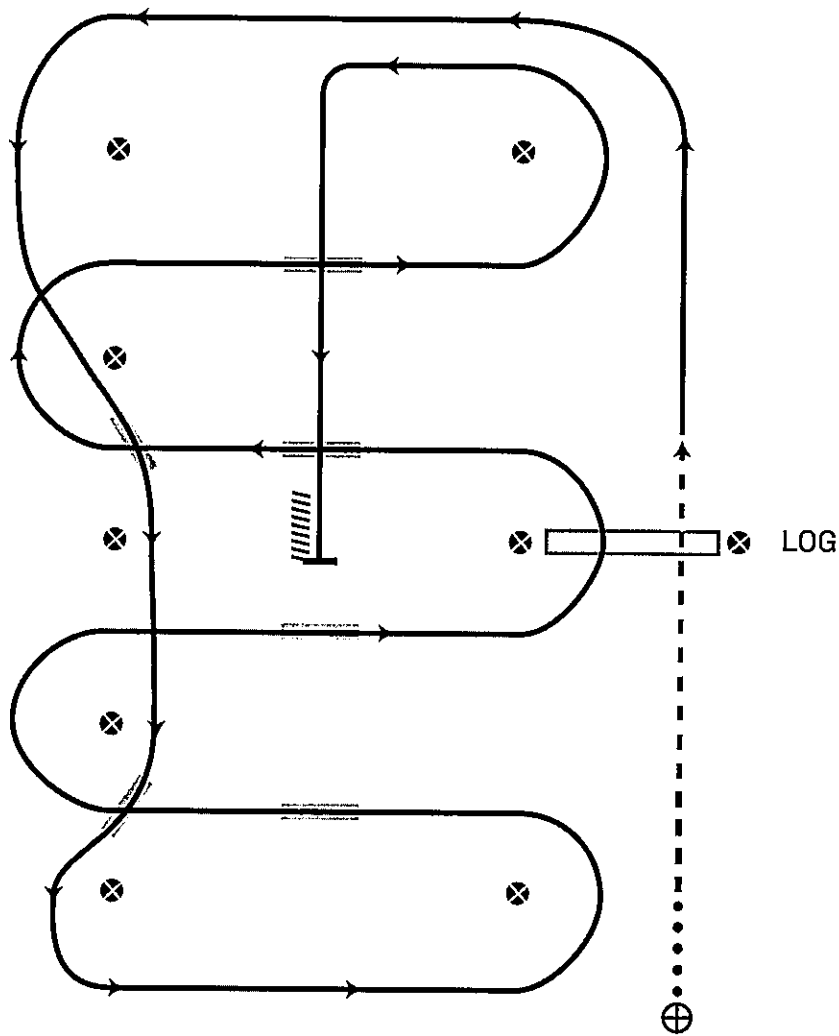

⊗ START CONE WALK JOG
 LEAD CHANGING AREA [shaded] LOPE ———

1. Walk at least 15 feet from start cone to the first marker, transition to jog, jog over log.
2. Transition to left lead & lope around end
3. First line change
4. Second line change lope around the end of arena
5. First crossing change
6. Second crossing change
7. Lope over log
8. Third crossing change
9. Fourth crossing change
10. Lope up the center, stop & back

WESTERN RIDING PATTERN I

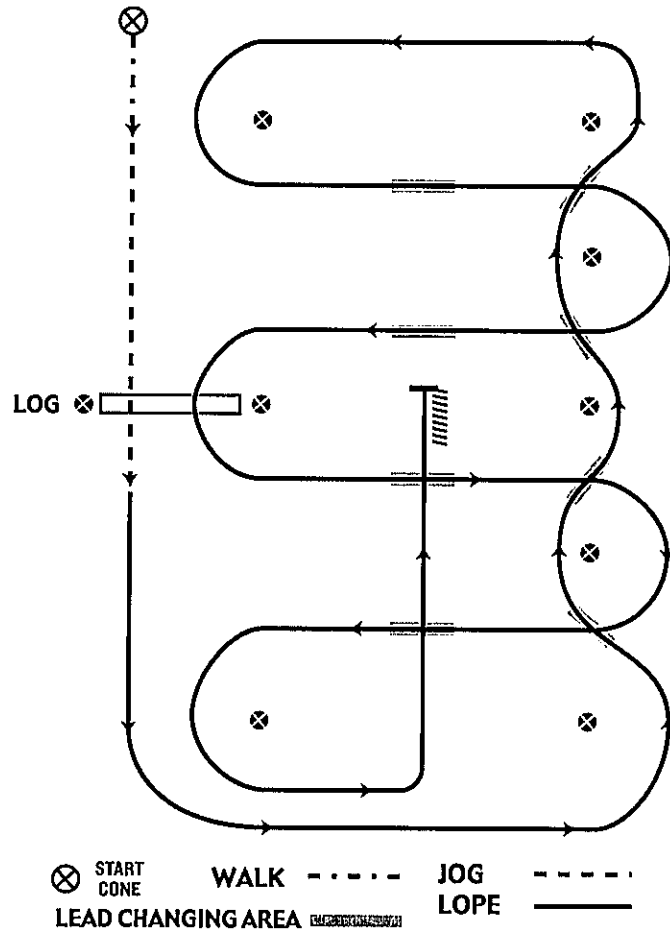

1. Walk at least 15' & jog over log
2. Transition to left lead & lope around end
3. First line change
4. Second line change
5. Third line change
6. Fourth line change lope around the end of arena
7. First crossing change
8. Second crossing change
9. Lope over log
10. Third crossing change
11. Fourth crossing change
12. Lope up the center, stop & back

2021 FOX LEA FARMS - FUN IN THE SUN
TUE JAN 12TH

AMATEUR AND SELECT TRAIL
YOUTH AND SENIOR TRAIL

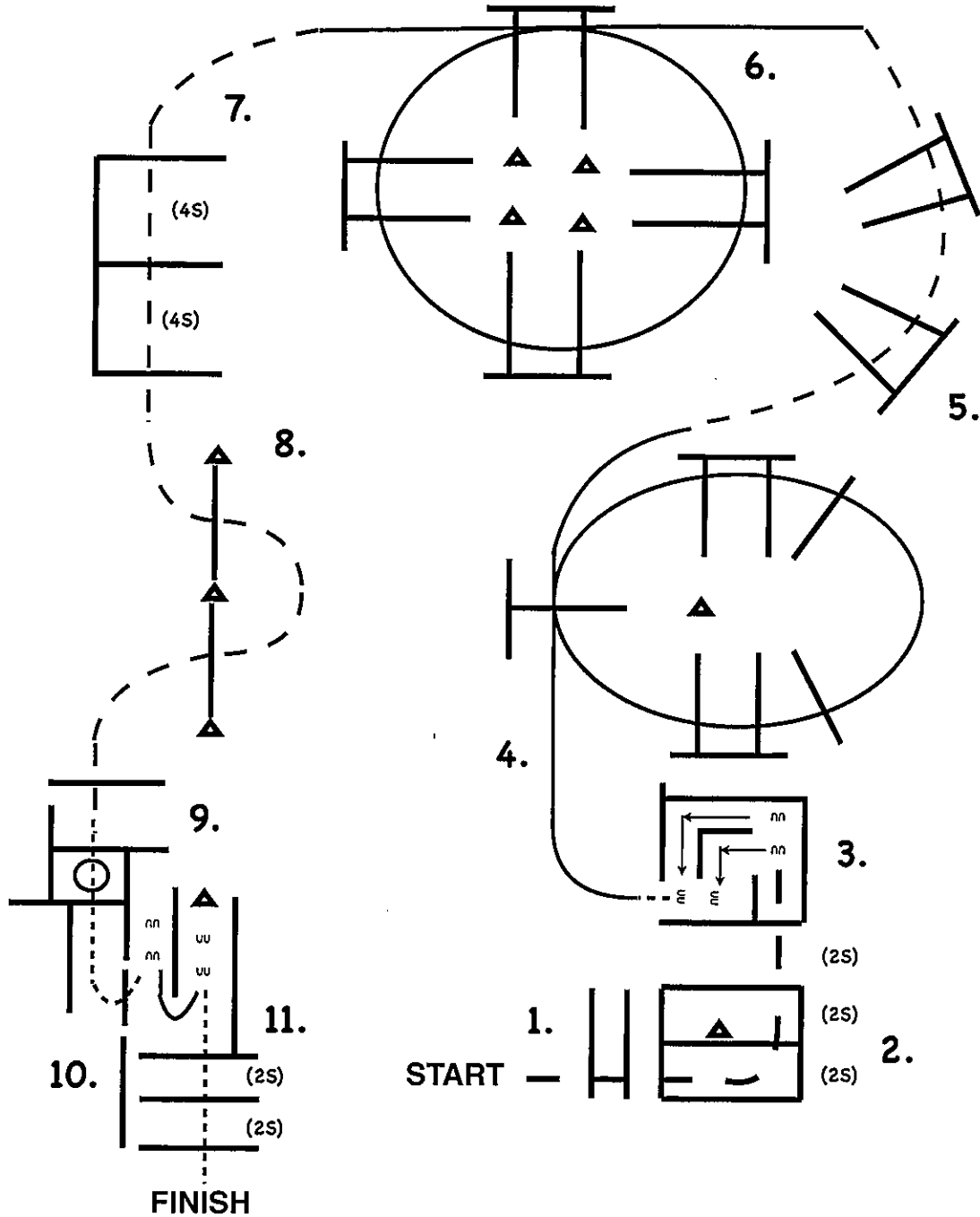

1. JOG OVER 3 POLES.
2. JOG OVER 3 MORE POLES, JOG INTO CHUTE.
3. SIDE PASS LEFT OVER POLES, WALK FORWARD.
4. LOPE OVER POLES (RIGHT LEAD).
5. BREAK TO THE JOG, JOG OVER POLES.
6. LOPE OVER POLES (LEFT LEAD)
7. BREAK TO THE JOG, JOG OVER POLES.
8. JOG THROUGH SERPENTINE, JOG OVER POLES.
9. JOG OVER POLE, AND STOP, WALK INTO BOX, EXECUTE A 360 TURN EITHER WAY, WALK OUT BOX.
10. WALK OVER POLE TURN LEFT, BACK BETWEEN POLES.
11. WALK OUT CHUTE, WALK OVER POLES.

2021 FOX LEA FARMS - FUN IN THE SUN
TUE JAN 12TH

L1 JR, L1 SR, L1 AM, L1 YOUTH

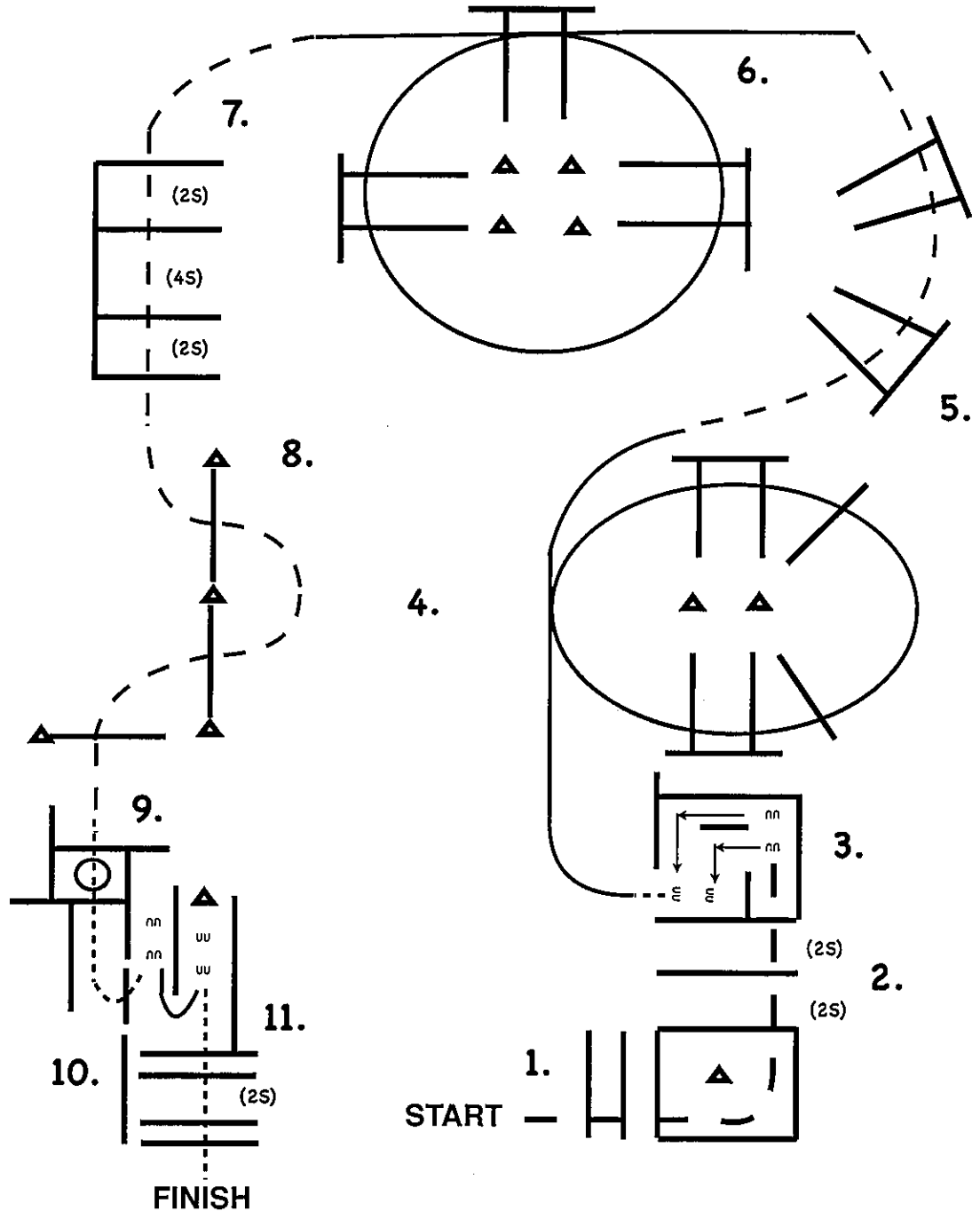

1. JOG OVER 3 POLES.
2. JOG OVER 3 MORE POLES, JOG INTO CHUTE.
3. SIDE PASS LEFT OVER POLE, THEN SIDE PASS LEFT AND WALK FORWARD.
4. LOPE OVER POLES (RIGHT LEAD).
5. BREAK TO THE JOG, JOG OVER POLES.
6. LOPE OVER POLES (LEFT LEAD)
7. BREAK TO THE JOG, JOG OVER POLES.
8. JOG THROUGH SERPENTINE, JOG OVER POLES.
9. STOP OR BREAK TO THE WALK, WALK INTO BOX, EXECUTE A 360 TURN EITHER WAY, WALK OUT BOX.
10. WALK OVER POLE TURN LEFT, BACK BETWEEN POLES.
11. WALK OUT CHUTE, WALK OVER POLES.

2021 FOX LEA FARMS - FUN IN THE SUN
TUE JAN 12TH

L1 AMATEUR WT TRAIL
L1 YOUTH WT TRAIL

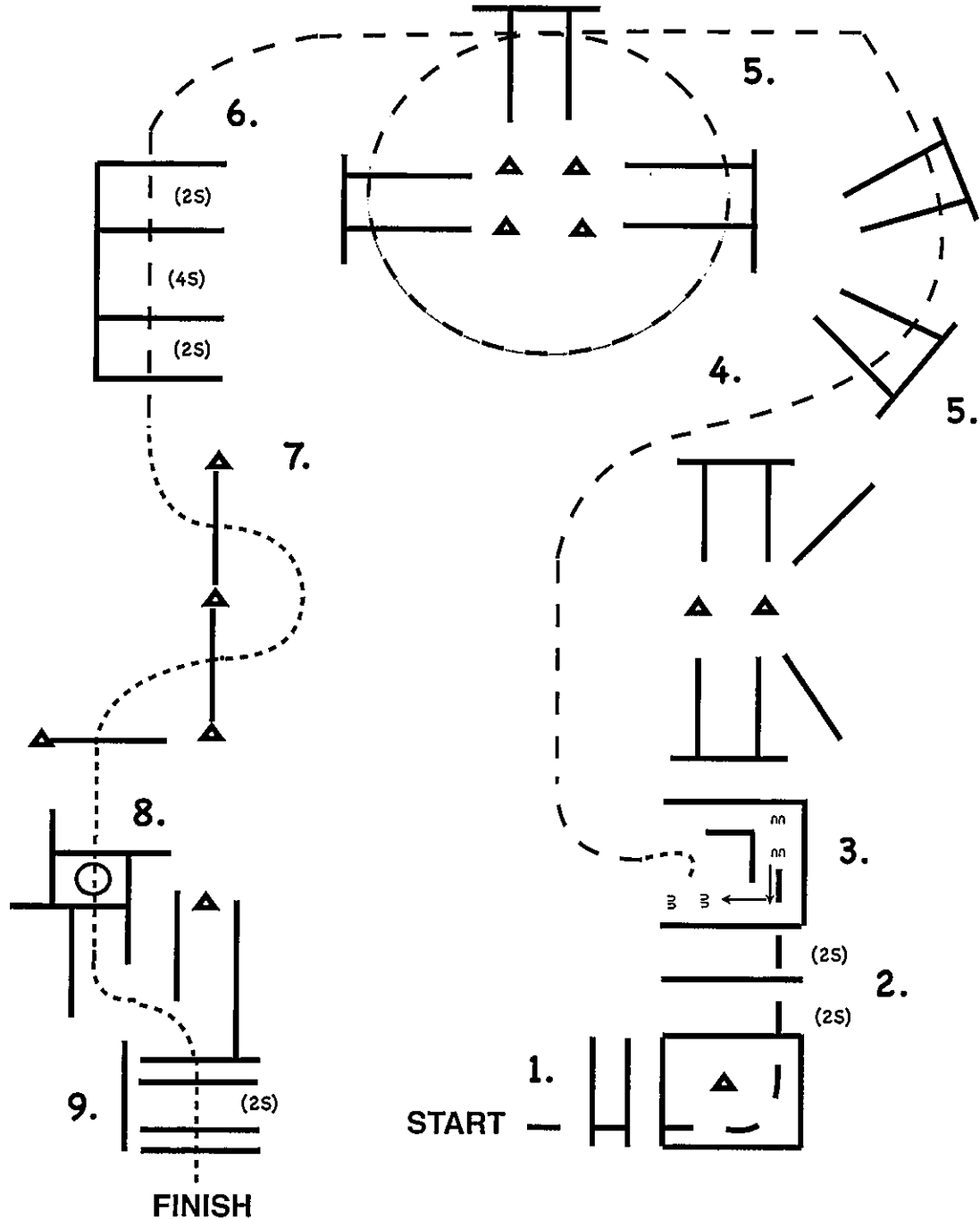

1. JOG OVER 3 POLES.
2. JOG OVER 3 MORE POLES, JOG INTO CHUTE.
3. BACK THROUGH POLES, TURN LEFT.
4. JOG OVER POLES.
5. JOG OVER POLES.
6. JOG OVER POLES.
7. STOP OR BRAK TO THE WALK, WALK THROUGH SERPENTINE, WALK OVER POLES.
8. WALK INTO BOX, EXECUTE A 360 TURN EITHER WAY, WALK OUT BOX.
9. WALK THROUGH CHUTE, WALK OVER POLES.